

# IRIScan™ Pro 5



Be Smart, Automate Your Scans!

## Contents

1. Introduction .....	3
2. Software Installation .....	4
2.1 Important Notes .....	4
2.2 Precautions .....	4
2.3 Installation .....	4
2.4 Activation .....	6
3. Supported Documents .....	6
4. Scanner Overview .....	7
4.1 Top View .....	7
4.2 Front View .....	7
4.3 Rear View .....	8
4.4 Side View .....	8
5. Preparing the Scanner .....	9
6. Using the IRIScan™ Pro 5 .....	9
7. Scanning Documents .....	10
7.1 Using the Automatic Document Feeder .....	10
7.2 Using the Front Feed Tray .....	13
7.3 Using the Rear Feed Tray .....	14
7.4 Ejecting Documents from the Opposite Tray .....	14
8. Maintenance .....	15
8.1 Clean the Scanner Glass, Separation Pad and Rollers .....	15
8.2 Replace the Feed Roller .....	16
8.3 Replace the Separation Pad .....	17
9. Troubleshooting .....	17
9.1 Clearing a Paper Jam .....	17
9.2 Error conditions .....	18
9.3 Questions and Answers .....	18
9.4 Product Support .....	19
10. Specifications .....	20
10.1 Scanner Specifications .....	20
10.2 System Requirements .....	20
11. Legal Information .....	21

## 1. Introduction

This User Guide helps you get started with the **IRIScan™ Pro 5**, a color sheetfed scanner.

Please read this guide before operating this scanner and its software. All information is subject to change without prior notice.

The IRIScan™ Pro 5 scanner is bundled with different **software packages**.

IRIScan™ Pro 5	IRIScan™ Pro 5 File	IRIScan™ Pro 5 Invoice
<p><b>Windows</b></p> <ul style="list-style-type: none"> <li>• Readiris™ Corporate</li> <li>• Cardiris™ Corporate</li> <li>• Button Manager</li> <li>• Capture Tool</li> </ul> <p><b>Mac OS</b></p> <ul style="list-style-type: none"> <li>• Readiris™ Corporate</li> <li>• Cardiris™</li> <li>• Capture Tool</li> </ul>	<p><b>Windows</b></p> <ul style="list-style-type: none"> <li>• IRISmart™ File</li> <li>• Readiris™ Corporate</li> <li>• Cardiris™ Corporate</li> <li>• Button Manager</li> <li>• Capture Tool</li> </ul>	<p><b>Windows</b></p> <ul style="list-style-type: none"> <li>• IRISmart™ Invoice</li> <li>• Readiris™ Corporate</li> <li>• Cardiris™ Corporate</li> <li>• Button Manager</li> <li>• Capture Tool</li> </ul>

For more information and detailed guidelines about our softwares: IRISmart™ File/Invoice, Readiris™, Cardiris™, the Button Manager and the Capture Tool, see their corresponding documentation on [www.irislink.com](http://www.irislink.com).

## 2. Software Installation

### 2.1 Important Notes

- Install Readiris™/IRISmart™ File **before** you connect the scanner to your computer.  
**Warning:** install the different software applications in the order indicated below.
- Check the [System Requirements](#) to make sure your system is compatible.

### 2.2 Precautions

- Keep the scanner out of direct sunlight. Direct exposure to the sun or excessive heat may cause damage to the unit.
- Do not install the scanner in a humid or dusty place.
- Be sure to use the proper AC power source.
- Place the scanner securely on an even, flat surface. Tilted or uneven surfaces may cause mechanical or paper-feeding problems.
- Retain the scanner box and packing materials for shipping purposes.

### 2.3 Installation

1. Go to [www.irislink.com/start](http://www.irislink.com/start).
2. Scroll down to **IRIScan™ Pro 5**.
3. Select the version you acquired and click **Getting Started**.
4. Then click **Start now**.
5. Complete the form and click **Register now**.
6. Select the required Operating System.
7. Click **Download** to download the software.
8. Go to the location where you downloaded the software, and run the installation file.
9. The following setup screen is displayed:  
**Warning:** install the different software applications in the order indicated below.  
IRISmart™ File/Invoice and Readiris™ must be installed before you install the scanner driver.



Click **IRISmart™ File** or **IRISmart™ Invoice** to install it. Follow the on-screen instructions.  
\*IRISmart™ File / IRISmart™ Invoice is only available if you acquired that specific bundle.

10. Click **Readiris™ Corporate** to install it. Follow the on-screen instructions.

11. Connect the scanner to your computer:

- Connect the micro USB connector to the USB port of the scanner.
- Connect the other end of the USB connector to a USB port on your computer.

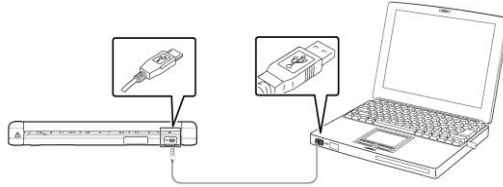

- Press the **Power** button to power on the scanner and click **Next** in the installation screen.

**Warning:** only use the USB cable delivered with your scanner. Using other USB cables may damage the scanner and void the warranty.

12. Return to the setup screen and click **IRIScan™ Pro Driver** to install the scanner driver.

13. Click **Next** and follow the on-screen instructions.

14. When the installation is done, click **Finish** and return to the setup screen.

15. Click **Button Manager** to install the Button Manager. A language selection window appears.

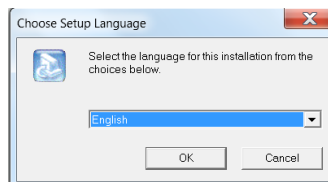

16. Choose the language you wish to install. The InstallShield wizard guides you through the rest of the installation.

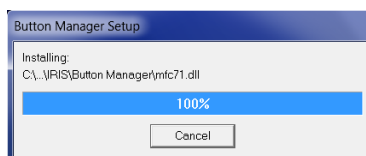

17. Click **Finish** to complete the installation.

18. Now install the application **Cardiris™**. Again follow the on-screen instructions.

**Warning:** the duplex function of IRIScan™ Pro 5 is not natively supported by Cardiris™ Mac, nor by the Button Manager when scanning to Cardiris™ PC. To learn how to scan in duplex to Cardiris™, consult our Knowledge base on <https://support.irislink.com/>.

## 2.4 Activation

The license number required to activate Readiris™ and Cardiris™ will be retrieved automatically on the condition that your scanner is connected to your computer by USB during activation process.

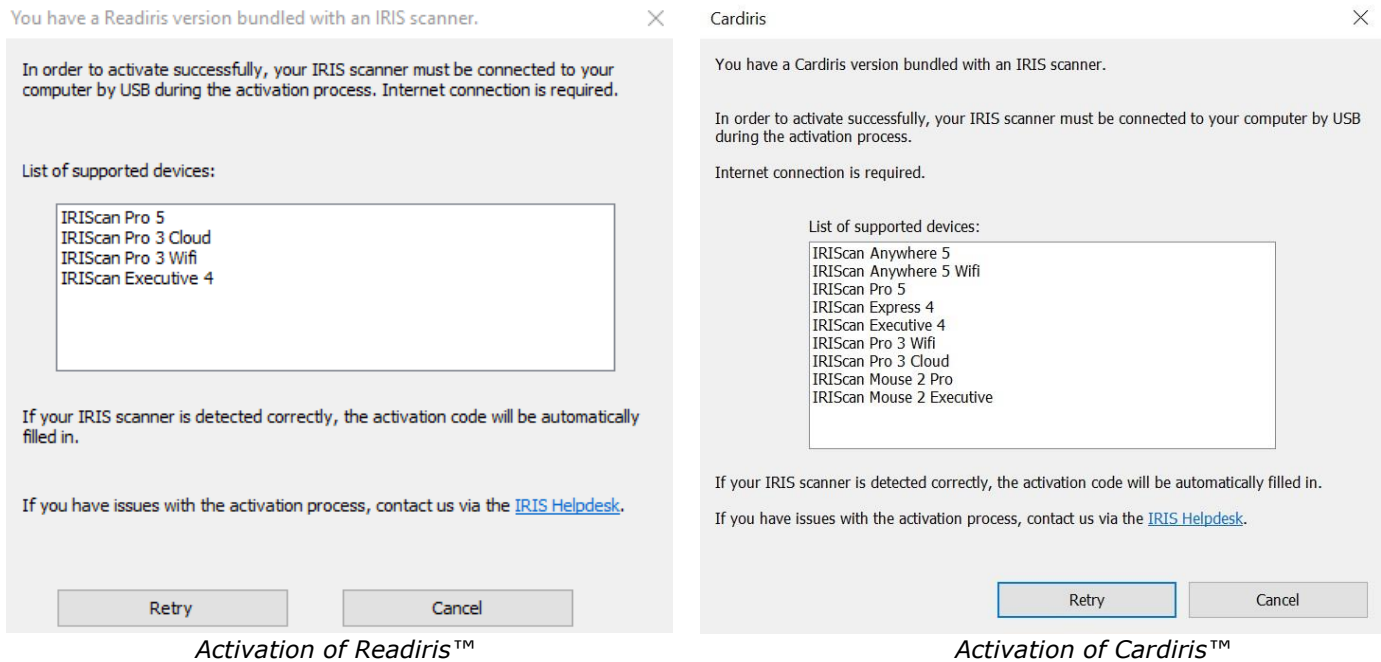

For detailed information about the full range of features of **Readiris™** or **Cardiris™**, consult the help file provided with the software, or the latest **User Guides** on <http://www.irislink.com/>.

## 3. Supported Documents

- Documents can range in size from 50 x 50 mm (1.9 x 1.9 in.) to 216 x 356 mm (8.5 x 14 in.)
- Documents can range in weight from 30 ~ 413 g/m<sup>2</sup> when using the Front Feed Tray.
- Documents can range in weight from 30 ~ 160 g/m<sup>2</sup> when using the Document Feeder.
- ID cards up to 1.25 mm (0.05 in.) thick
- Documents should be square or rectangular and in good condition (not fragile or worn).
- Documents should be free of curl, wrinkle, tears, wet ink, or punch holes.
- Documents should be free of staples, paper clips, sticky notes.

## 4. Scanner Overview

### 4.1 Top View

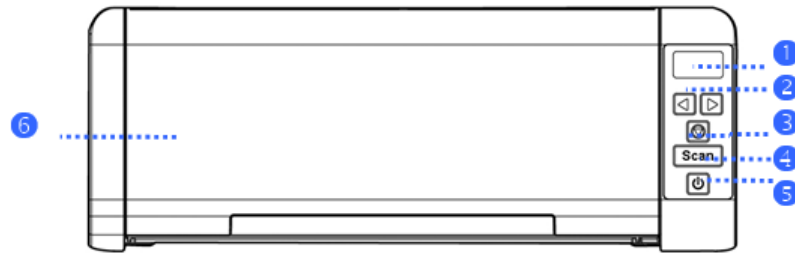

1	LCD Display	Displays the function button.
2	Right/Left arrow	Press to switch between the different function buttons.
3	Cancel button	Press to cancel an ongoing scanning job.
4	Scan button	Press to start scanning to the configured software application or to the Button Manager.
5	Power button	Press to power on the scanner.
6	Automatic Document Feeder (ADF)	This tray is used for feeding multiple documents. Open it to use the scanner as sheet-fed scanner.

### 4.2 Front View

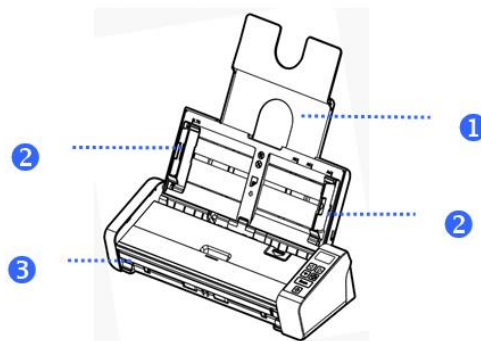

1	Document Extension Plate	Open the plate to support the document when loading a long document.
2	Document Guides	These guides ensure documents are fed straight. Raise the guides when loading a document, and then align them to the edges of the document to be scanned.
3	Front Feed Tray	Insert a document to scan from the front feed tray.

### 4.3 Rear View

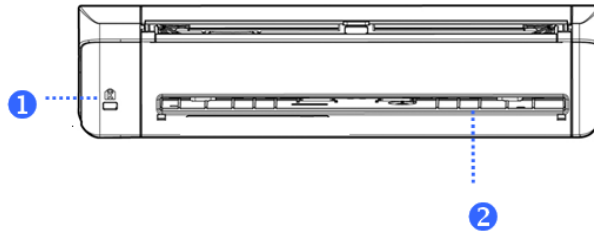

1	Kensington Security Slot	Attach to a lock to secure the scanner.
2	Rear Feed Tray	Insert a document to scan from the rear feed tray.

### 4.4 Side View

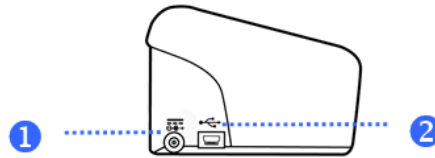

1	Power Jack	Connect the AC adapter to the scanner.
2	Micro USB port	Plug the micro end of the USB cable in this port and connect the other end of the cable to a computer.



## 5. Preparing the Scanner

### Connect the Scanner to a Power Outlet

Plug the small end of the power adaptor into the power jack of your scanner. Insert the other end into an appropriate power outlet.

Note that the power adapter can be modified to European, American and Asian power outlets.

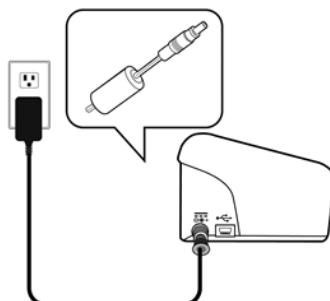

Connect the scanner to your computer as described in [2. Software Installation](#).

### Power on the Scanner

Press the **Power** button on the front panel. The Power button led now flashes. When it stops flashing and is steadily on, the scanner is ready to scan.

To power off the scanner, press the **Power** button for 3 seconds.

## 6. Using the IRIScan™ Pro 5

The IRIScan™ Pro 5 can be used in several ways:

- With the **Button Manager** to scan documents directly to Readiris™ for text recognition, scan them to other applications of your choice, to multiple Cloud destinations, etc.
- From within **IRISmart™ File/Invoice**, **Readiris™** or **Cardiris™**.
- From within the **Capture Tool**.

In section [7. Scanning Documents](#) of this Quick User Guide we only describe the basics how to scan. For more information on how to scan from within IRISmart™ File/Invoice, Readiris™, Cardiris™, the Button Manager and the Capture Tool, see their separate User Guides. They can be found on our [website](#).

**Warning:** when scanning from within Readiris™ and IRISmart™ File/Invoice, the **Scanner Properties** window pops up before each scan. In this window you can configure advanced scan settings. These scan settings are the same as the ones that are available in the **Capture Tool**. For detailed information about the scan settings, see the separate **Capture Tool** User Guide on our [website](#).

## 7. Scanning Documents

Documents can be scanned in various ways by the IRIScan™ Pro 5:

- You can scan stacks of up to 20 documents in the Document Feeder.
- You can load documents one by one in the Front Feed Tray.
- You can load documents one by one in the Rear Feed tray.

### 7.1 Using the Automatic Document Feeder

**Warning:** to avoid occasional paper jams, please fan your documents and align the top edges before feeding them into the scanner.

- Hold both ends of the documents and fan them a few times.



- Rotate the documents by 90 degrees and fan them in the same manner.
- Align the edges of the documents in a step-like pattern as indicated below.

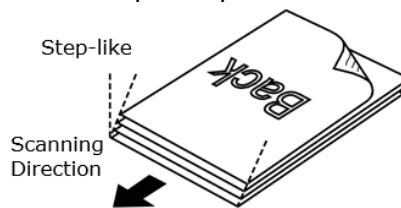

**Warning:** the document feeder of the IRIScan™ Pro 5 is L-shaped, meaning your documents will be bent going through the feeder. If you need to scan documents that must not be bent, such as ID cards or credit cards for instance, use the Front or Rear Feed Tray.

## Loading Documents in the Document Feeder

1. Unfold the document feeder and its extension.

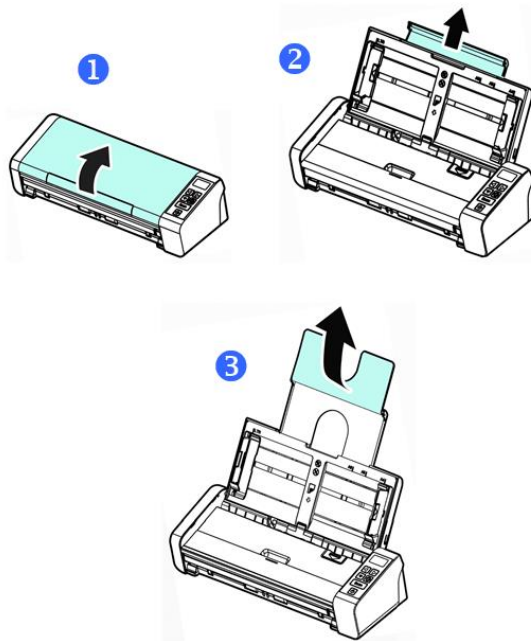

2. Adjust the paper guide to hold your documents.

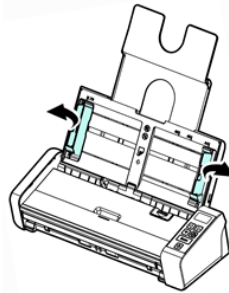

3. Load the stack of documents, **top edge first** and **text facing up**.

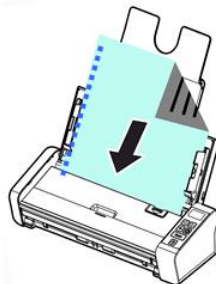

4. Verify that the paper guides are aligned with the edges of the stack.
5. Verify that the front feed tray is closed.
6. Press the **Scan** button to start scanning.

**TIP for loading stacks of documents of various sizes and weights**

When scanning a batch of documents with different sizes and weights, be sure to follow these guidelines to avoid a skewed image or a paper jam:

1. Align the documents **top edge first** and arrange the pages from large to small.

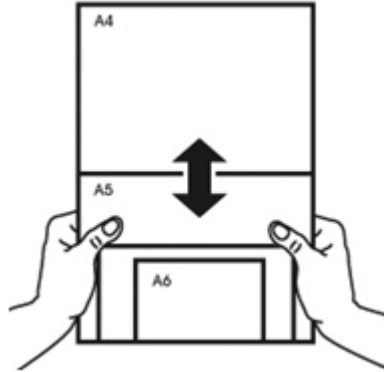

2. If two pages are of the same size but of different weight, arrange these pages from heavy to light.

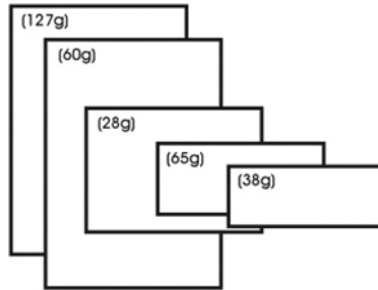

3. Align the edges of the documents by tapping the bottom of the stack against a table top.

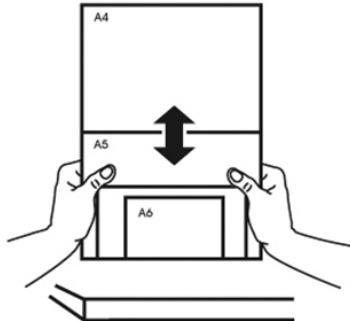

4. Center these pages in the document feeder and make sure that the edges of the largest page slightly touch the Paper Guides.

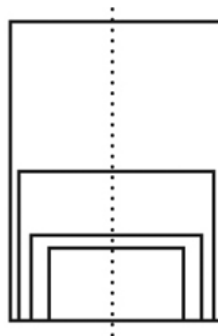

### What to do in case of a Multi-Feed

Even if you have fanned your documents properly it is still possible that a Multi-Feed occurs. A Multi-Feed is when two or more pages accidentally go through the feeder at the same time.

By default, the IRIScan™ Pro 5 detects when a Multi-Feed occurs and on which page, and activates an error sound effect.

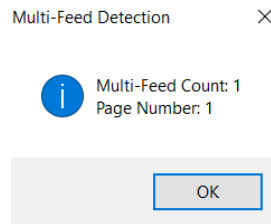

This way you know which page needs to be scanned again.

If you want the scanner to stop scanning next time a Multi-Feed occurs, go to the **Multi-Feed Detection** tab in the **Scanner Properties** window and select **Stop Scanning after Multi-Feed**. This way you need to rescan all the documents you tried to scan.

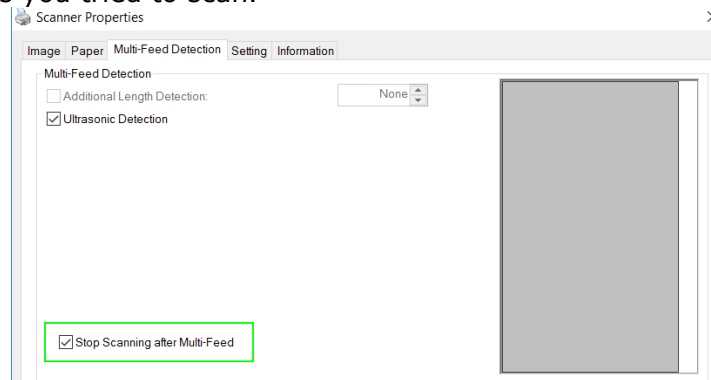

## 7.2 Using the Front Feed Tray

**Warning:** the Front Feed Tray scans **one page** at a time. Do *not* insert multiple pages.

1. Open the cover of the front feed tray.

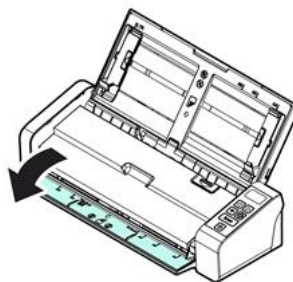

2. Use the paper size marks to center your single-page document.
3. Load your document into the front feed tray, **top edge first** and **text facing up**. The scanner automatically grabs and secures the document.

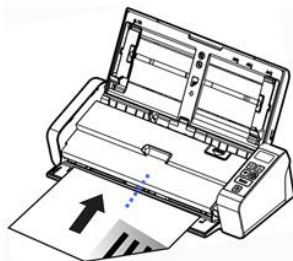

4. Press the **Scan** button to start scanning.

## 7.3 Using the Rear Feed Tray

**Warning:** the Rear Feed Tray scans **one page** at a time. Do *not* insert multiple pages.

1. Use the paper size marks to center your single-page document.
2. Load your document into the rear feed tray, **top edge first** and **text facing up**.
3. Gently push the document into the feed tray as indicated.  
The rear feed tray does *not* automatically grab and secure the document.

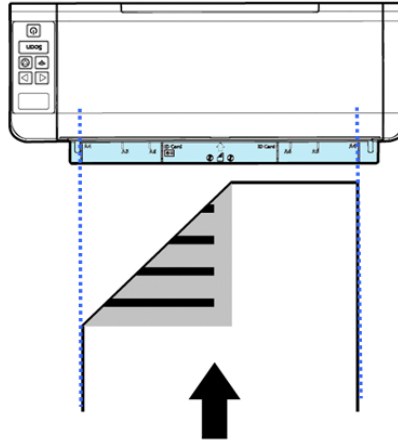

4. Press the **Scan** button to start scanning.

## 7.4 Ejecting Documents from the Opposite Tray

If you are feeding paper from the front or rear feed tray, the scanner provides two eject paths: documents are by default ejected from the same side of the feed tray, but they can also be ejected from the opposite side.

To eject documents from the opposite tray:

- Go to the **Setting** tab in the **Scanner Properties** window.
- Select **Eject Paper Opposite**.

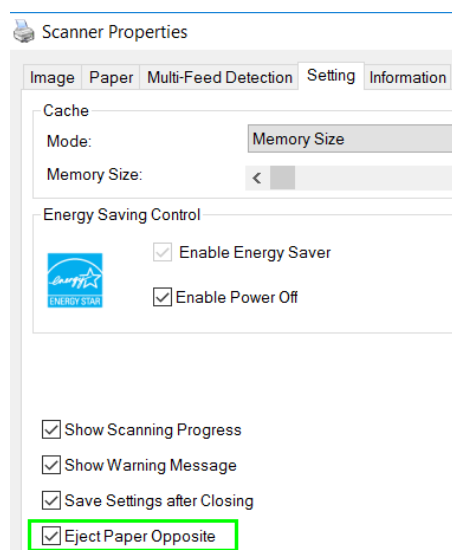

## 8. Maintenance

### 8.1 Clean the Scanner Glass, Separation Pad and Rollers

If the scanned images contain streaks or scanned documents become dirty, the scanning glass, the separation pad and the roller inside the scanner are likely to be dirty. Clean them periodically.

Use only the recommended or supplied tool to clean the scanner and feeder dock.

#### Cleaning steps:

1. Open the feed tray.

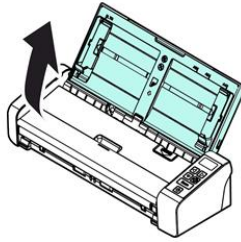

2. Press the ADF Release button to open the feeder cover.

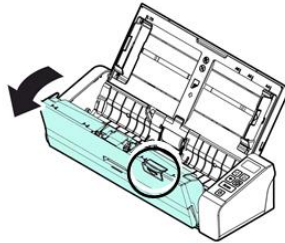

3. Wipe the separation pad, rollers and the glass with the cleaning cloth.

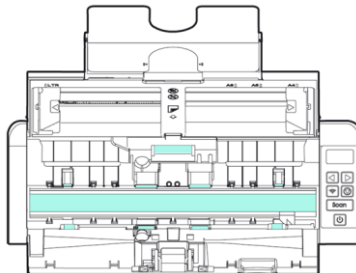

---

#### Note:

- Adding some isopropyl alcohol (95%) on the cleaning cloth is more efficient when cleaning the rollers.
  - Do not use any solvents or corrosive liquid (*i.e., alcohol, kerosene, etc.*) to clean any part of the scanner, otherwise the plastic material will be permanently damaged.
-

## 8.2 Replace the Feed Roller

The feed roller and separation pad inside the scanner wear with scanning. If the feed roller and separation pad are worn, documents may not feed correctly and paper jams may occur. When document feed performance deteriorates, replace the feed roller and separation pad.

It is recommended to replace the feed roller or separation pad when the total number of pages of documents fed in the scanner exceeds one of the following quantities:

Feed Roller: 100,000 sheets

Separation Pad: 30,000 sheets

### To replace the Feed Roller:

1. Open the feed tray.
2. Press the ADF Release button to open the feeder cover.
3. Open the roller cover.

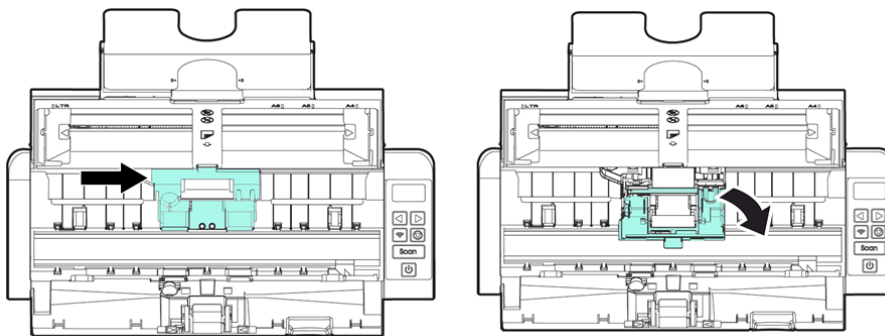

4. Slide the feed rollers to the left as indicated below.
5. Remove the feed rollers.

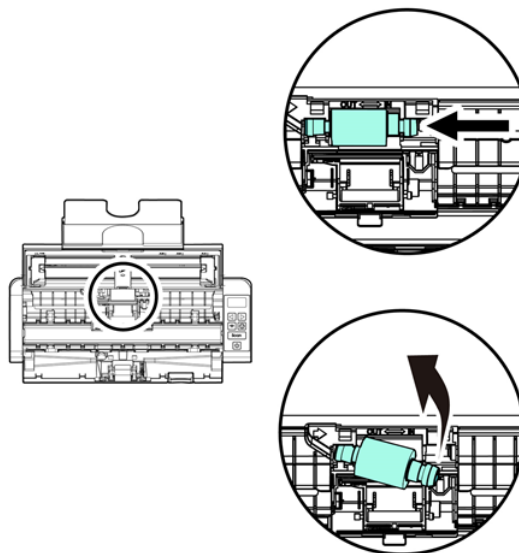

6. Attach the new feed rollers. Insert the left end of the shaft to the notch and slide the feed roller to the right.
7. Completely close the roller cover so that it clicks into place.
8. Close the feeder cover.



## 8.3 Replace the Separation Pad

1. Open the feed tray.
2. Press the ADF Release button to open the feeder cover
3. Press the two arms of the separation pad inwards with two fingers and lift it up to remove the separation pad. The two arms are indicated by blue arrows.

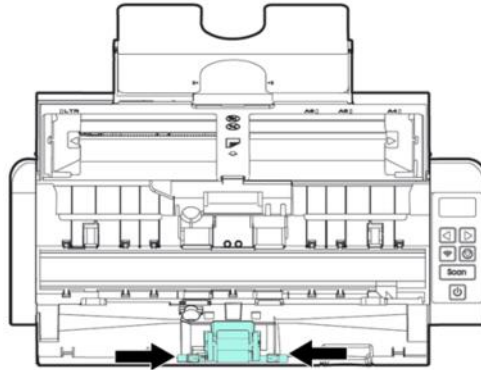

4. Hold the two arms of the separation pad with two fingers and attach the new separation pad to the scanner.

## 9. Troubleshooting

### 9.1 Clearing a Paper Jam

In the event of a paper jam follow the instructions below to remove the paper:

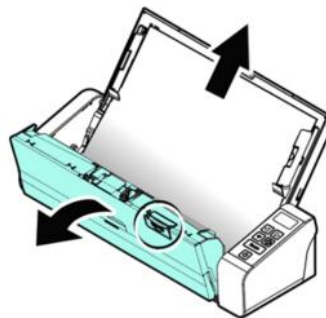

1. Press the document feeder release button to open the feeder cover.
2. Carefully pull the paper out of the feed tray.
3. Close the feeder cover.
4. Place the paper correctly in the document feeder and the scanner automatically continues your scan.

**TIP:** if you want to start all over, click **Cancel**.



## 9.2 Error conditions

If there is error during scanning, the LED light will be flashing in red and an error icon will be displayed. Refer to the following table to clear the error conditions.

Error icon	Cause	Solution
<b>Paper jam</b> 	<ol style="list-style-type: none"> <li>1. Original has become stuck in the feeder.</li> <li>2. Original exceeds max. length 300 dpi: 36" (914mm), 600 dpi: 14" (356mm)]</li> </ol>	Open the feeder cover and pull the original out of the feeder.
<b>Cover opens</b> 	<ol style="list-style-type: none"> <li>1. Feeder cover opens.</li> </ol>	Close the feeder cover.

## 9.3 Questions and Answers

<b>Question:</b>	<b>Paper becomes jammed or multi-fed</b>
<b>Answer:</b>	<ol style="list-style-type: none"> <li>1. Flatten the corners and edges of your documents.</li> <li>2. Thoroughly fan your documents before loading them into the scanner. Documents might stick together because of static electricity.</li> <li>3. Reduce the number of pages that you simultaneously load into the scanner.</li> </ol>
<b>Question:</b>	<b>Paper becomes skewed in the scanner</b>
<b>Answer:</b>	<ol style="list-style-type: none"> <li>1. Align the document guides to fit the documents as closely as possible and place the documents so that they feed in straight.</li> <li>2. Check the condition of the feeding roller. If necessary, follow the cleaning directions in <a href="#">Section 8.1</a> and perform the cleaning.</li> </ol>
<b>Question:</b>	<b>Why does my scanned image always come out too dark?</b>
<b>Answer:</b>	<ol style="list-style-type: none"> <li>1. Please adjust the screen settings to SRGB.</li> <li>2. Please adjust the brightness settings on the screen in the application software.</li> </ol>
<b>Question:</b>	<b>Why are there strange lines on the scanned document?</b>
<b>Answer:</b>	<p>Please check the following:</p> <ol style="list-style-type: none"> <li>1. Are there scratches on the original or is the original clean ?</li> <li>2. Remove any stains or dust from the original before scanning.</li> <li>3. Clean the rollers and glass with the included cleaning cloth. (Refer to the <a href="#">Section 8.1</a>)</li> </ol>

<b>Question:</b>	<b>When I choose 600 dpi as optical resolution, why are the "auto crop" and "deskew" functions disabled?</b>
<b>Answer:</b>	Since performing auto crop and deskew consumes great deal of system memory, it is recommended to select an optical resolution below 600 dpi to prevent errors.

## [9.4 Product Support](#)

Should you still experience issues using the IRIScan™ Pro 5, consult our [Technical Support](#).

## 10. Specifications

### 10.1 Scanner Specifications

Model Number :	IRIScan™ Pro 5
Paper Feeding:	ADF 20-page capacity
Scanning Technology:	Contact Image Sensor (CIS)
Document Size:	Min. 50 x 50 mm (1.9 x 1.9 in.) Max. 216 x 356 mm (8.5 x 14 in.)
Scanning Speed:	20 PPM / 40 IPM (Color, A4, 200 dpi) 15 PPM / 30 IPM (Color, A4, 300 dpi)
Paper Thickness:	30 ~ 413 g/m <sup>2</sup> (Front Feed Tray) 30 ~ 160 g/m <sup>2</sup> (ADF)
ID Card Thickness:	Up to 1.25 mm (0.05 in.) (Embossed side face up, landscape feeding, Front Tray)
Long Page Mode:	3000 mm, 118 in.
Optical Resolution:	600 dpi
Output Resolution:	75, 100, 150, 200, 300, 400 and 600 dpi
Output Formats:	BMP, PNG, GIF, JPEG, Single-Page PDF, Multi-Page PDF, Multi-TIFF and TIFF.
Interface/Drivers:	USB 2.0 / TWAIN, ISIS
Power Supply:	Input: 100-240 VAC, 50/60 Hz Output: 24V, 1.5A
Power Consumption:	Operation: <24 W Ready: <7.5 W Sleep: <2.5 W Off: <0.32W
Environmental Factors:	Operating temperature: 10°C ~ 35°C (50°F ~ 95°F) Operating humidity: 10% to 85%
Dimensions: (HxWxD)	299 x 104 x 74 mm (11.6 x 4.0 x 2.91 in.)
Weight:	1.4 kg (3.3 lb.)
Recommended Daily Scanning Volume:	1,000 sheets

### 10.2 System Requirements

#### For Windows®

CPU:	Intel Core 2 Duo or higher
Memory:	Minimum 1 GB RAM. 2 GB RAM is recommended
Hard disk space:	1.5GB of available hard disk space.
Operating System:	Windows 10, Windows 8.1, Windows 8, Windows 7. All 32 or 64 bit.
USB:	USB 2.0 Port

#### For macOS® - a Mac® computer with Intel® processor

Memory:	5GB RAM
Hard disk space:	1GB of available hard disk space
Operating System:	macOS® 10.12 or above
USB:	USB 2.0 Port

The system requirements and compatibility can change over time, depending on the operating system and updates from Microsoft/Apple.

To get the most up to date requirements, you can check the [Support Page](#) on our website.

## 11. Legal Information

### Copyright

© 2019 I.R.I.S SA. All rights reserved.

The software described in this document is furnished under a license agreement or nondisclosure agreement. The software may be used or copied only in accordance with the terms of those agreements. No part of this publication can be reproduced in any form or by any means without prior written permission of I.R.I.S. SA.

Material scanned by this product may be protected by governmental laws and other regulations, such as copyright laws, the customer is solely responsible for complying with all such laws and regulations.

### Documentation version 19-1.1

Specifications of this software and contents of this user manual are subject to change without notice. Any modification, error correction, or feature updates made in the actual software may have not been timely updated in this user manual. You may refer to the software itself for more accurate details. Any misprints, translation error, or inconsistent with existing software, will be updated timely.

This documentation uses fictitious names as examples; references to actual persons, companies or organizations are strictly coincidental.

### Trademarks

The IRIScan™ Pro is a trademark of Image Recognition Integrated Systems S.A.

Microsoft® is a U.S. registered trademark of Microsoft Corporation.

Windows®, Windows 7, Windows 8 and Windows 10 are either registered trademarks or trademarks of Microsoft Corporation in the United States and/or other countries.

Microsoft and Windows are registered trademarks of Microsoft Corporation.

Energy Star® is a registered trademark of the U.S. government.

Other names and products mentioned in this document may be trademarks or registered trademarks of their respective companies.

### Warranty

I.R.I.S. makes no warranty of any kind with regard to this material, including, but not limited to, the implied warranties of fitness for a particular purpose.

I.R.I.S. shall not be liable for errors contained herein or for incidental or consequential damages in connection with the furnishing, performance, or use of this material.

### Safety Instructions

Follow these safety instructions when setting up and using the scanner:

- Read all these instructions, and follow all warnings and instructions given in this document.
- Place the scanner close enough to the computer for the interface cable to reach it easily.
- Never handle the scanner with damp or wet hands, in nomadic mode, or when used as a fixed unit.
- When connecting this product to a computer or other device with a cable, ensure the correct orientation of the connectors. Each connector has only one correct orientation. Inserting a connector in the wrong orientation may damage both devices connected by the cable.
- Other than placing a mini SD card or new batteries in the openings provided for the purpose and indicated on the scanner, do not insert objects into any opening as they may touch dangerous voltage points or short out parts and lead to a risk of electrocution.
- Place the product on a flat, stable surface large enough to safely hold the product and the document to be scanned.
- Never disassemble the scanner.
- If the product overheats or produces smoke or an unusual odour, discolours or becomes deformed in an abnormal way, immediately turn off the scanner, remove the batteries where applicable, and disconnect the cables. Stop using the scanner and contact your dealer or IRIS customer support to receive instructions on the procedure to follow.
- Take care not to drop the scanner or expose it to physical impacts.

- Do not place or store the scanner outdoors, in a car, near heat sources, in locations that are dusty, damp or exposed to impact, vibration, condensation, high temperatures, sunlight, strong light, or rapid changes in temperature or humidity.
- Never attempt to disassemble, modify, or repair the scanner or any of its components yourself.

### *FCC Regulations*

This equipment has been tested and found to comply with the limits for a Class B digital device, pursuant to Part 15 of the FCC Rules. These limits are designed to provide reasonable protection against harmful interference in a residential installation. This equipment generates, uses, and can radiate radio frequency energy and, if not installed and used in accordance with the instruction manual (available at [www.irislink.com/start](http://www.irislink.com/start)) that may cause harmful interference to radio communications.

However, there is no guarantee that interference will not occur in a particular installation. If this equipment does cause harmful interference to radio or television reception, which can be determined by turning the equipment off and on, the user is encouraged to try to correct the interference by one or more of the following measures:

- Increase the separation between the equipment and receiver.
- Connect the equipment into an outlet on a circuit different from that to which the receiver is connected.
- Consult the dealer or an experienced radio/TV technician for help.

This device complies with Part 15 of the FCC Rules. Operation is subject to the following two conditions: (1) This device may not cause harmful interference, and (2) this device must accept any interference received, including interference that may cause undesired operation. Changes and modifications to this equipment not specifically approved by IRIS may void the user's authority to operate this equipment. Shielded cables must be used with this equipment to maintain compliance with FCC regulations.



### *European Union Regulatory Notice*

Products bearing the CE marking comply with the following EU Directives:

- Low Voltage Directive 2014/35/EC
- EMC Directive 2014/30/EC
- Restriction of the use of certain hazardous substances (RoHS) Directive 2011/65/EU
- RED (Radio Equipment Directive) (2014/53/EC)

CE compliance of this product is valid if powered with the correct CE-marked AC adapter provided by I.R.I.S. s.a.

This product satisfies the Class B limits of EN55022, EN55024, safety requirements of EN 60950 and ROHS requirements of EN50581.

\*This product is certified as Class 1 LED product.



## *Disposal of Waste Equipment by Users in Private Households in the European Union*



This symbol on the product or on its packaging indicates that the product can not be disposed of with your other household waste. Instead it should be sent to appropriate facilities for recovery and recycling in an effort to protect human health and the environment. For more information about where you can drop off your waste equipment for recycling, please contact your local city office, your household waste disposal service or the shop where you purchased the product.

